

FORGE TUN HEROS



HERKULES
FITNESS EN PLEIN AIR





Nous sommes convaincus que l'activité physique est essentielle à la santé et au bien-être mental ainsi qu'aux interactions sociales. Surtout aujourd'hui, il est de plus en plus important de disposer d'espaces sportifs en plein air sûrs, accessibles et gratuits, où l'on peut faire de l'exercice, se détendre et rompre avec le stress quotidien. Et cela quel que soit l'âge ou le niveau de forme physique.

FR

En 2024, année des Jeux Olympiques de Paris, nous avons été fournisseurs officiels de la Ville de Paris, une référence qui illustre notre engagement pour l'accessibilité sportive. Depuis plus de 15 ans, nous créons des équipements de fitness et de loisirs en plein air, polyvalents et accessibles à tous les âges et niveaux (même pour les chiens !).

Présent dans presque toute l'Europe grâce à nos nombreux distributeurs, nos bureaux principaux sont basés à Paris et Chrzanów, en Pologne, où se trouvent le siège et les entrepôts modernes. À ce jour, nous avons installé plus de 3700 parcs sportifs en accès libre et sécurisé et nous continuons de croître à l'échelle mondiale. Aujourd'hui, nous renforçons encore notre engagement à innover et à introduire constamment de nouveaux produits pour rendre le sport gratuit et accessible partout dans le monde. Parce que le sport devrait être accessible, à tous, partout.

We are convinced that physical activity is essential for health and mental well-being as well as for social interactions. Especially today, it is increasingly important to have safe, accessible, and free outdoor sports spaces where one can exercise, relax, and break away from daily stress. And this is true regardless of age or fitness level.

EN

In 2024, the year of the Paris Olympic Games, we were an official supplier to the City of Paris, a distinction that underscores our commitment to sports accessibility. For over 15 years, we have been creating versatile outdoor fitness and leisure equipment that is accessible to all ages and levels (even for dogs).

Present in almost all of Europe through our many distributors, our main offices are based in Paris and Chrzanów, Poland, where the headquarters and warehouses are located. To date, we have installed more than 3,700 free-access sports parks and we continue to grow worldwide. Today, we are strengthening our commitment to innovate and to constantly introduce new products to make sport free and accessible everywhere in the world. Because sport should be accessible to everyone, everywhere.

Victoria Syska & Antoine Allaux
Herkules Fitness

PRODUCTION ET QUALITÉ

PRODUCTION AND QUALITY

Tous nos équipements sont fabriqués à partir de tubes en acier inoxydable ou en acier galvanisé à chaud de 3 mm d'épaisseur, qui sont ensuite soudés dans des machines individuelles. Les mâts principaux ont un diamètre de 114 mm, ce qui garantit robustesse et longévité. Toutes les pièces structurelles ont jusqu'à 10 ans de garantie et sont résistantes aux intempéries.

All of our equipment is made from either stainless steel or hot-dip galvanized steel pipes 3mm thick, which are then welded into individual machines. The main poles are 114 mm in diameter which grants sturdiness and longevity. All structural parts have up to 10 years warranty and are weather-resistant.

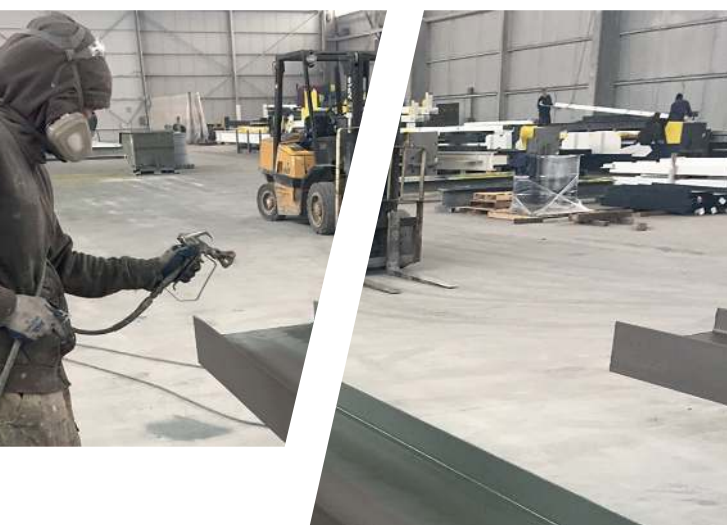

Les pièces soudées sont ensuite nettoyées des résidus graisseux par sablage. Pour protéger davantage l'équipement, chaque machine est recouverte d'une couche primaire à base de zinc.

The welded parts are then cleaned of greasy residues by sandblasting. To further protect the equipment, each machine is coated with a zinc-based primer.

En dehors de la série en acier inoxydable, chaque équipement est ensuite recouvert d'une épaisse couche de peinture statique Dupont qui est ensuite cuite dans un four à 200 degrés.

Apart from the stainless steel series, each piece of equipment is then covered with a thick layer of Dupont static paint which is then baked in an oven at 200 degrees.



PRODUCTION ET QUALITÉ

PRODUCTION AND QUALITY



Tous nos roulements sont des roulements fermés en acier inoxydable fabriqués par le fabricant renommé DSK Japan. De plus, toutes les vis et roulements sont protégés par des couvercles antivols 100% inoxydables. Les poignées sont fabriquées à partir de caoutchouc 100% recyclable, ce qui garantit une prise ferme et confortable pendant l'exercice.

All of our bearings are closed stainless steel bearings made by renowned manufacturer DSK Japan. Additionally, all of the screws and bearings are protected by 100% stainless anti-theft covers. The handles are made from 100% recyclable rubber which ensures a firm and comfortable grip during exercise.



DESIGN ET INNOVATION

DESIGN AND INNOVATION

L'innovation est au centre de notre métier. Afin de répondre aux besoins du plus grand nombre, et à des usages en évolution permanente, nous développons constamment de nouvelles lignes, en utilisant les dernières technologies et des solutions toujours plus créatives. Les pistons en aluminium, les poids réglables sécurisés ou le chargement de téléphone sans contact intégré à nos appareils ne sont que quelques-uns de nos derniers développements!

Tous nos appareils sont conçus en collaboration avec des sportifs professionnels, afin de proposer des exercices efficaces, adaptés à toutes les morphologies et à tous les niveaux. Depuis notre création en 2007, nous avons progressivement élargi notre offre afin de proposer des appareils toujours plus performants. Aujourd'hui, nos agrès s'adressent aussi bien aux promeneurs et sportifs du dimanche qu'à des athlètes de haut niveau voulant pratiquer en extérieur.

Nos équipements sont imaginés, prototypés et testés par nos équipes dans un seul but : rendre le sport extérieur accessible et performant pour tous!

Innovation is at the heart of our business. In order to meet the needs of the greatest number, and to constantly changing uses, we are constantly developing new lines, using the latest technologies and ever more creative solutions. Aluminum pistons, secure adjustable weights or the contactless phone charging built into our devices are just a few of our latest developments!

All our devices are designed in collaboration with professional athletes, in order to offer effective exercises, adapted to all body types and to all levels. Since our creation in 2007, we have gradually expanded our offer in order to offer ever more efficient devices. Today, our equipment is aimed at both walkers and Sunday athletes as well as high-level athletes who want to practice outdoors.

Our equipments are designed, prototyped and tested by our teams with a single goal: to make outdoor sport accessible and efficient for all!



CERTIFICATION ET SECURITÉ

CERTIFICATION AND SAFETY

Que nos parcs sportifs soient installés dans des clubs sportifs, des hotels, des bases militaires ou au milieu de l'espace public, chacun doit pouvoir pratiquer en toute sécurité. C'est pour cela que la sécurité est au coeur de nos préoccupations. Nos appareils sont conçus avec les meilleurs matériaux et procédés de fabrication, afin de leur conférer une grande durabilité dans le temps et d'offrir une utilisation en toute sécurité tout au long de leur vie.

Chaque agrès Herkules a été testé contre une utilisation intensive et les intempéries, afin de répondre au cahier des charges défini par nos équipes et d'obtenir leur certification à la norme européenne EN 16630:2015.

La réglementation européenne définit dans l'article EN 16630:2015 les conditions de sécurité à remplir dans la production, l'assemblage et l'installation d'appareils sportifs d'extérieur. Tous les appareils Herkules sont conçus pour répondre scrupuleusement à ces règles, afin d'assurer la sécurité de nos utilisateurs : hauteurs de chute, zones de coincement, roulements avec butée, valises de poids sécurisées.

Whether our sports parks are located in sports clubs, hotels, military bases or in the middle of public space, everyone must be able to practice in complete safety. This is why security is at the heart of our concerns. Our devices are designed with the best materials and manufacturing processes, to give them great durability over time and offer safe use throughout their life.

Each Herkules equipment has been tested against intensive use and bad weather, in order to meet the specifications defined by our teams and to obtain their certification to European standard EN 16630: 2015.

European regulations define in article EN 16630: 2015 the safety conditions to be fulfilled in the production, assembly and installation of outdoor sports equipment. All Herkules devices are designed to strictly comply with these rules, in order to ensure the safety of our users: fall heights, jamming zones, bearings with stopper, secure weight cases.



AFFICHAGE DISPLAY



Chaque agrès Herkules Fitness est équipé d'un panneau d'information fixe et durable. Chaque plaque comprend des informations sur les exercices, sa fonction, des conseils sur la façon de faire de l'exercice ainsi qu'un code QR qui mène à une application Herkules Fitness gratuite avec des vidéos tutorielles. Les panneaux sont en 2-3 langues et contiennent les mentions légales nécessaires, les restrictions concernant l'utilisation de l'équipement et les coordonnées d'urgence.

Each Herkules Fitness machine is equipped with a permanently fixed, durable informational panel. Every plate includes information regarding the exercises, its function, advice on how to exercise as well as a QR code which leads to a free Herkules Fitness App with tutorial videos. Panels are in 2-3 languages and contain the necessary legal notice, restrictions regarding the use of equipment and emergency contact information.



En plus de l'affichage sur les appareils, la présence d'un panneau d'information général est obligatoire sur une aire fitness. Notre panneau est entièrement personnalisable selon vos besoins. Au-delà des informations requises légalement, nous pouvons personnaliser le panneau avec votre logo, vos couleurs, et toutes informations complémentaires.

In addition to the display on the equipment, the presence of a general information panel is mandatory on a fitness area. Our panel is fully customizable according to your needs. In addition to the legally required information, we can customize the sign with your logo, colors, and additional informations.

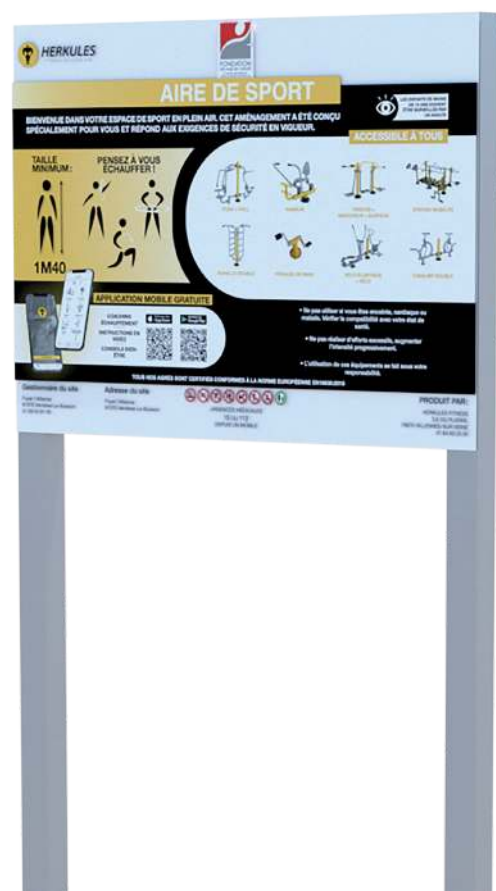

ACCOMPAGNEMENT PROJECT SUPPORT

Avec plus de 15 ans d'expérience, nous connaissons le monde du fitness en plein air mieux que quiconque. Par conséquent, nous sommes là pour vous aider à choisir et à concevoir l'espace fitness de vos rêves. Nous vous accompagnons dans le choix des appareils et de leur disposition, afin que ceux-ci répondent aux besoins de votre public, tout en s'intégrant au mieux dans leur environnement. Nous pouvons également fournir des intégrations 3D sur photo pour mieux vous projeter dans votre futur parc fitness.

With over 15 years of experience, we know the outdoor fitness world better than anyone. Therefore, we are here to help you choose and design your dream fitness area. We support you in the choice of equipment and its arrangement, so that it meets the needs of your audience, while integrating as well as possible into their environment. We can also provide 3D photo integrations to better project you in your future fitness park.



Avant :



Après :



RÉSEAU DE DISTRIBUTION

DISTRIBUTION NETWORK

Nous travaillons avec plusieurs partenaires de proximité pour nous permettre d'être au plus proche de nos clients, que ce soit en France ou à l'étranger.

Nos agences partenaires nous permettent de couvrir l'entièreté du territoire français ainsi qu'une large partie de l'Europe et du monde, afin de vous faire parvenir vos agrès le plus rapidement possible.

Ces agents commerciaux et installateurs se déplacent dans votre région pour vous conseiller et vous accompagner dans votre projet.

Nous proposons également le service d'installation partout en France. Nous pouvons vous aider à concevoir et à choisir la disposition, le revêtement de sol et la petite architecture. Pour vous garantir longévité et sécurité à votre aire, nos équipes d'installateurs sont formées spécifiquement à nos produits.

Si vous êtes une collectivité locale, vous pouvez vous rapprocher de notre distributeur dans votre région.

La planification et le coût de chaque installation dépendent de nombreux facteurs, contactez-nous pour obtenir un devis.

We work with several local partners to allow us to be closer to our customers, whether in France or abroad.

Our partner agencies allow us to cover the entire French territory as well as a large part of Europe and the world, in order to send you your equipment as quickly as possible.

These sales agents and installers travel to your region to advise you and support you in your project.

We also offer the installation service everywhere in France. We can help you design and choose layout, flooring and small architecture. To guarantee the longevity and safety of your area, our teams of installers are specifically trained in our products.

If you are a local authority, you can approach our distributor in your region.

The planning and cost of each installation depends on many factors, contact us for a quote.



NOS PARTENAIRES

OUR PARTNERS

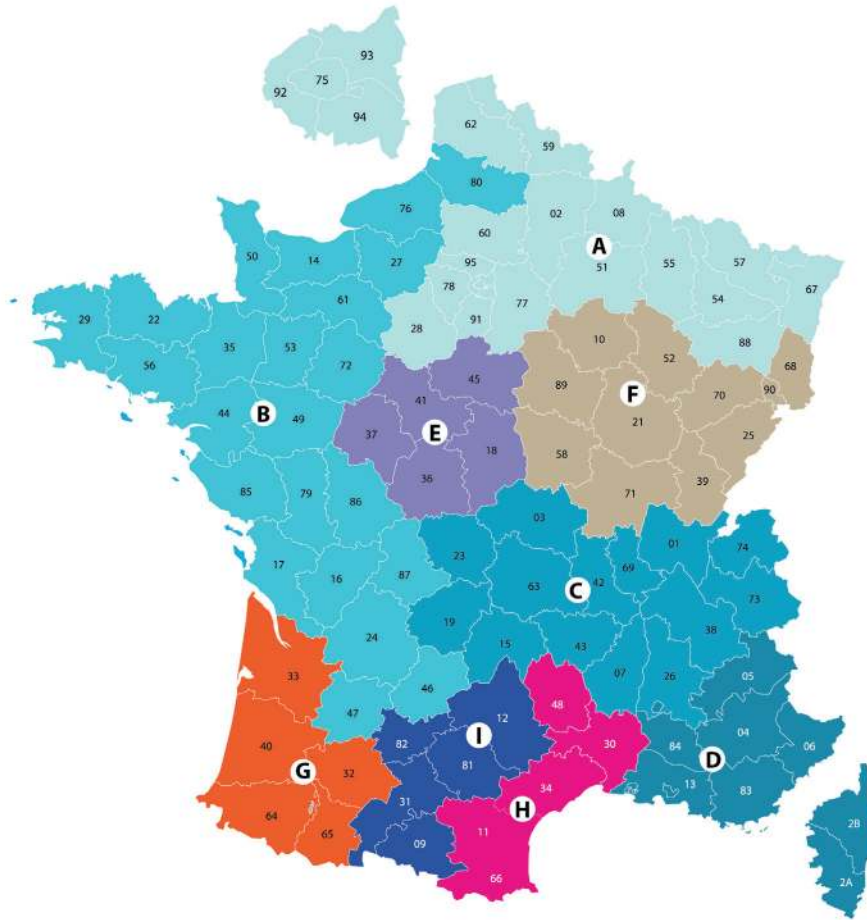

QUALI-Cité

A

Île-De-France

01 69 90 88 90

idf@quali-cite.com

QUALI-Cité

B

Bretagne/Atlantique

02 97 42 80 37

bretagne@quali-cite.com

QUALI-Cité

C

Auvergne/Rhône-Alpes

02 97 42 80 37

rhône-alpes@quali-cite.com

QUALI-Cité

D

Méditerranée

04 78 82 95 01

mediterranee@quali-cite.com

Sif'Equip

E

02 47 72 15 66

contact@siteequip.com

AJ3M

F

03 80 45 43 91

contact@aj3m.fr

Sonesdi

G

05 56 37 91 39

sonesdi@sonesdi.com

Win'Ovatio

H

04 88 60 54 93

direction@winovatio.fr

Atmosphères

I

07 83 63 00 68

info@atmospheres.fr



Utform

0413-20 000

info@utform.se



GEA Fun Experience

+39 0521 853262

laurac@geaitalia.com



QUALI-Cité GmbH

+49 0681 9963 320

f.reinacher@quali-cite.com

INSTALLATION

L'installation est une étape cruciale dans la mise en place de votre parc fitness, afin de garantir longévité et sécurité. Nos équipes d'installateurs partenaires réparties à travers toute l'Europe sont formés spécifiquement à nos produits, afin de garantir une installation dans les règles de l'art.

Deux méthodes d'installation sont possibles en fonction du type d'appareil et de la nature du sol. Les pieds peuvent être fixés par scellement chimique directement dans une dalle en béton ou boulonnés à des tabourets d'ancrage Herkules sur un sol naturel.

Le revêtement de finition du sol joue également un rôle essentiel, autant pour l'esthétique, l'entretien, l'accessibilité et la sécurité. En effet, à partir d'une certaine hauteur de chute, le sol doit avoir certaines propriétés amortissantes. Nos installateurs ont tout le savoir faire pour vous proposer différents types de finition : gazon naturel, synthétique, sol souple EPDM, gravillons, pavés, sable...

Installation is a crucial step in setting up your fitness park, in order to guarantee longevity and safety. Our partner installers throughout Europe are trained to ensure proper installation.

Two installation methods are possible depending on the type of device and the type of soil. The legs can be chemically sealed directly into a concrete slab or bolted to Herkules anchor stools.

The floor finish also plays an essential role, as much for aesthetics, maintenance, accessibility and safety. Indeed, from a certain fall height, the ground must have certain damping properties. Our installers have all the know-how to offer you different types of finish: natural turf, synthetic turf, flexible EPDM soil, gravel, paving stones, sand, etc.

Dalles EPDM



Nike Grind, chaussures de sport



Gazon synthétique



Corkeen, liège naturel



EPDM



Gravillons



Pavés



Sol Naturel



Béton



Sable



VIDÉO PROFESSIONNELLE

PROFESSIONAL VIDEO

Nous savons à quel point un projet de parc fitness en plein air peut être passionnant et engageant! Il se passe parfois plusieurs mois entre le premier contact et l'ouverture du parc, et un tel projet mérite d'être mis en valeur. C'est pourquoi nous proposons un service de réalisation de vidéo, afin que vous puissiez communiquer sur votre nouveau parc fitness au sein de votre communauté.

Nos vidéos sont réalisées et montées par des vidéastes professionnels disposant de caméra haute définition, de stabilisateurs électroniques et de drones. De quoi vous fournir un support de communication idéal pour partager sur vos réseaux sociaux et sites internet.

Vous voulez voir à quoi cela ressemble? Visitez notre page Youtube!

We know how exciting and engaging an outdoor fitness park project can be! Sometimes several months pass between the first contact and the opening of the park, and such a project deserves to be highlighted. This is why we offer a video production service, so that you can communicate about your new fitness park within your community.

Our videos are made and edited by professional videographers with high definition cameras, electronic stabilizers and drones. Enough to provide you with an ideal communication medium to share on your social networks and websites.

Want to see what it looks like? Visit our Youtube page!

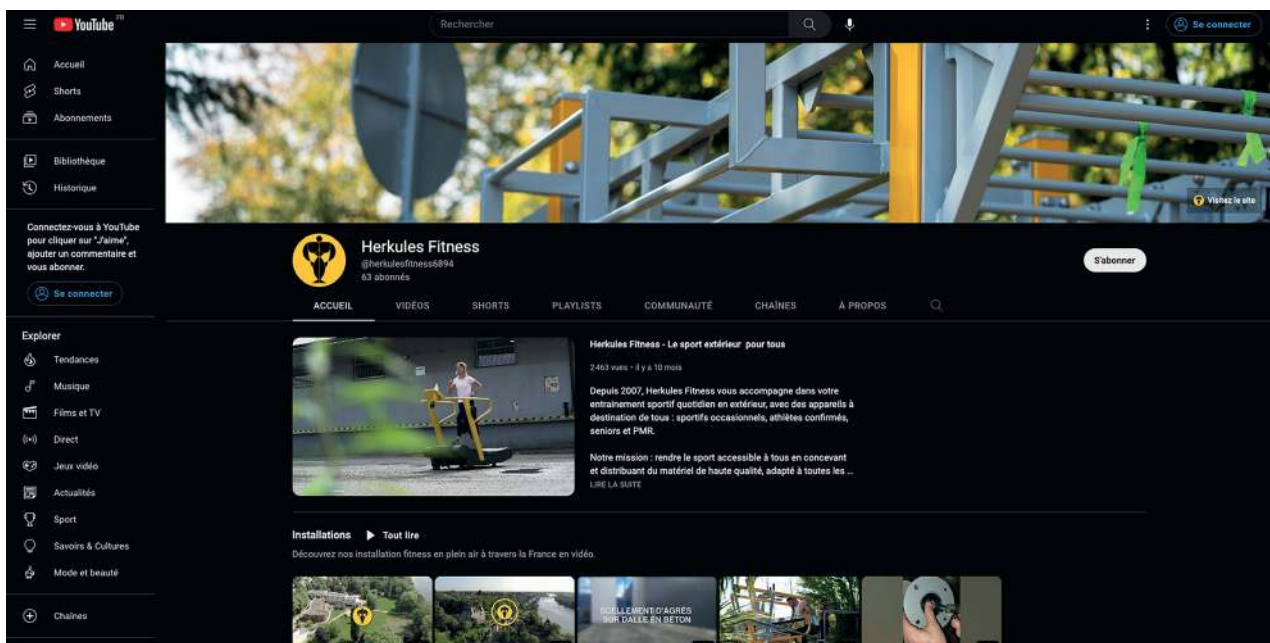

APPLICATION MOBILE HERKULES FITNESS

HERKULES FITNESS MOBILE APP



DISPONIBLE GRATUITEMENT SUR :
FREE AVAILABLE ON:



- COACHING ÉCHAUFFEMENT
- CONSEILS BIEN-ÊTRE ET SPORTIFS
- INSTRUCTIONS D'UTILISATION
- VIDÉO EXPLICATIVE

- WARM-UP COACHING
- WELL-BEING AND SPORTS TIPS
- DETAILED INSTRUCTIONS
- VIDEO EXPLANATION

Dans un contexte de dérèglement climatique, Herkules Fitness s'engage dans une démarche responsable et durable, afin de limiter nos effets négatifs sur l'environnement.

Nos appareils sont recyclables à 99% et nos emballages sont issus de matériaux recyclés.

De plus, nous soutenons l'action de l'ONG One Tree Planted, une organisation non gouvernementale engagée dans la protection des forêts à travers le monde. Concrètement, elle plante des arbres dans des zones protégées, afin de créer des forêts, éléments indispensables à la vie sur Terre, véritables poumons de la planète.

En plus de nos dons réguliers, nous finançons la plantation d'un arbre pour chaque appareil Herkules installé. Lors de la mise en place de votre projet, vous pouvez choisir le lieu de plantation, et recevoir un certificat One Tree Planted.

In response to climate change, Herkules Fitness is committed to a responsible and sustainable approach to minimize our negative effects on the environment.

Our equipment is 99% recyclable, and our packaging is made from recycled materials.

Moreover, we support the efforts of One Tree Planted, a non-governmental organization dedicated to forest protection around the world. Specifically, it plants trees in protected areas to create forests, which are essential for life on Earth and act as the planet's lungs.

In addition to our regular donations, we fund the planting of a tree for every Herkules device installed. When setting up your project, you can choose the planting location and receive a One Tree Planted certificate.



ONETREEPLANTED

**1 APPAREIL
INSTALLÉ
=
1 ARBRE
PLANTÉ**



HERKULES
FITNESS EN PLEIN AIR





FITNESS CLASSIC



Une série complète d'exercices accessibles à tous les niveaux, pour pratiquer le sport tout en douceur.

A versatile series of machines accessible to all levels, to practice sport smoothly.



PUSH DOUBLE

Ref: THJ-BO1

Dim: 2306 x 762 x 1909 mm



PUSH SIMPLE

Ref: THJ-BO1S

Dim: 1303 x 762 x 1909 mm



DOUBLE PULL

Ref: THJ-BO2

Dim: 2315 x 742 x 1909 mm



PULL SIMPLE

Ref: THJ-BO2S

Dim: 1307 x 742 x 1909 mm



FITNESS



PUSH + PULL

Ref: THJ-BO1 + BO2

Dim: 2317 x 762 x 1909 mm



STRETCH

Ref: THJ-BO3

Dim: 949 x 924 x 1220 mm



VÉLO ELLIPTIQUE

Ref: THJ-BO4

Dim: 1170 x 641 x 1655 mm



MASSEUR DOS ET HANCHES

Ref: THJ-BO5

Dim: 1462 x 783 x 1491 mm





TRIPLE BARRE DE TRACTION

Ref: THJ-BO6

Dim: 1877 x 1649 x 2210 mm



RAMEUR

Ref: THJ-BO8

Dim: 1406 x 1087 x 10112 mm



DOUBLE SURFEUR

Ref: THJ-B10

Dim: 1272 x 852 x 1488 mm



SURFEUR

Ref: THJ-B10S

Dim: 795 x 852 x 1488 mm

FITNESS



SURFEUR + MACHEUR + TWISTER

Ref: THJ-B10 + B11 + B16

Dim: 2635 x 806 x 1397 mm



SURFEUR + MARCHEUR + STEPPER

Ref: THJ-B10 + B11 + B25

Dim: 2337 x 805 x 1397 mm



TWISTER + SURFEUR

Ref: THJ-B10 + B16

Dim: 1584 x 853 x 1502 mm



MARCHEUR

Ref: THJ-B11

Dim: 1207 x 482 x 1442 mm





ROUES TAI CHI

Ref: THJ-B12

Dim: 1285 x 1160 x 1416 mm



GRANDE ROUE + ROUE TAI CHI

Ref: THJ-B12 + B19

Dim: 1160 x 1137 x 1761 mm



DOUBLE LEG PRESS

Ref: THJ-B13

Dim: 2348 x 472 x 1791 mm



LEG PRESS SIMPLE

Ref: THJ-B13S

Dim: 1324 x 472 x 1791 mm

FITNESS



BANC ABDOS SIMPLE

Ref: THJ-B14S

Dim: 1538 x 1048 x 581 mm



BANCS ABDOS DOUBLE

Ref: THJ-B14

Dim: 1533 x 1237 x 757 mm



ABDOS + LOMBAIRE

Ref: THJ-D10A+L/B

Dim: 1973 x 1533 x 1400 mm



ÉCHELLE DOUBLE

Ref: THJ-D14E/B

Dim: 1582 x 1019 x 2081 mm





CHAISE ROMAINE DOUBLE

Ref: THJ-DI4C/B

Dim: 2541 x 665 x 1957 mm



ÉCHELLE + CHAISE ROMAINE

Ref: THJ-DI4+DI6/B

Dim: 2062 x 1019 x 2081 mm



TRIPLE TWISTER

Ref: THJ-B16

Dim: 1807 x 1570 x 1364 mm



TWISTER + STEPPER

Ref: THJ-B16 + B25

Dim: 1428 x 853 x 1487 mm

FITNESS



BARRES PARALLÈLES

Ref: THJ-B17

Dim: 1950 x 562 x 1608 mm



CAVALIER

Ref: THJ-B18

Dim: 1305 x 665 x 1297 mm

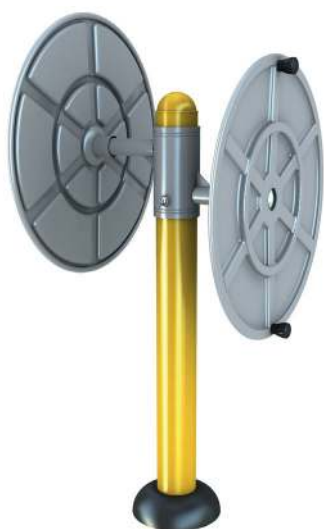

GRANDES ROUES

Ref: THJ-B19

Dim: 900 x 891 x 1761 mm



PATINEUR

Ref: THJ-B22S

Dim: 1164 x 590 x 1655 mm





DOUBLE PATINEUR

Ref: THJ-B22

Dim: 1266 x 554 x 1647 mm



LEG LIFT

Ref: THJ-B23

Dim: 884 x 828 x 1198 mm



DOUBLE ADDUCTEUR

Ref: THJ-B24

Dim: 1289 x 666 x 1364 mm



STEPPER

Ref: THJ-B255

Dim: 757 x 592 x 1331 mm

FITNESS



DOUBLE STEPPER

Ref: THJ-B25

Dim: 1214 x 590 x 1331 mm



DOUBLE TWISTER MASSANT

Ref: THJ-B26

Dim: 1517 x 798 x 1556 mm



ÉCHELLE À ÉTIREMENT

Ref: THJ-B27

Dim: 685 x 420 x 1963 mm



VÉLO

Ref: THJ-B28

Dim: 1076 x 516 x 1296 mm





ARM PRESS

Ref: THJ-B29

Dim: 1556 x 774 x 1023 mm



LOW PULL UP

Ref: THJ-B30

Dim: 1278 x 662 x 962 mm



ABDOMINAL

Ref: THJ-B31

Dim: 1210 x 612 x 1605 mm



TWISTER DEBOUT & ASSIS

Ref: THJ-B32

Dim: 1726 x 742 x 1343 mm

FITNESS



VÉLO BRAS

Ref: THJ-B33

Dim: 817 x 610 x 1375 mm



PÉDALES DE BANC

Ref: THJ-B34

Dim: 525 x 410 x 296 mm

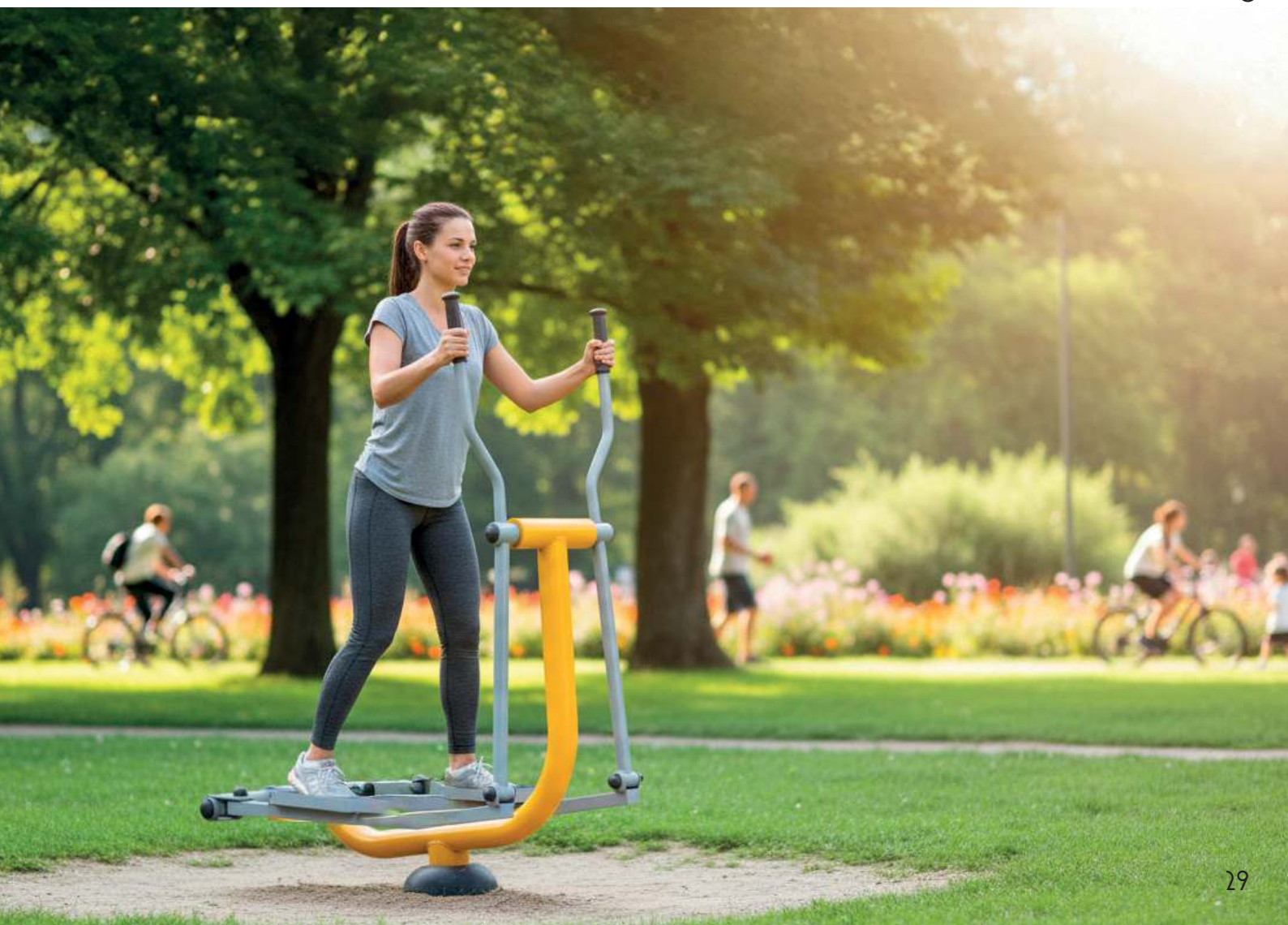



FITNESS MIX



Créez votre espace fitness sur mesure avec des milliers de combinaisons possibles grâce à nos pylônes 2, 3 et 4 faces.

Create your tailor-made fitness space with thousands of possible combinations thanks to our 2, 3 and 4-sided pylons.

1 - Choisissez vos agrès selon vos besoins et vos envies.

Choose your equipments according to your needs and your desires.

2 - Le pylône s'adapte au nombre d'agrès que vous avez choisi.

The pylon adapts to the number of equipments you have chosen.



3 - Votre agrès simple, double, triple ou quadruple est prêt !

Your single, double, triple or quadruple equipment is ready!



+ PERSONNALISABLES

+ CONVIVIAUX

+ LUDIQUES

— DE COÛT D'INSTALLATION

— D'EMPRISE AU SOL

FITNESS MIX



PYLÔNE 2 FACES

Ref: THJ-CO2

Dim: 300 x 550 x 1997 mm



PYLÔNE 3 FACES

Ref: THJ-CO3

Dim: 555 x 555 x 1957 mm



PYLÔNE 4 FACES

Ref: THJ-CO4

Dim: 570 x 570 x 1957 mm



POTEAU M

Ref: THJ-PO2

Dim: 350 x 300 x 1400 mm



POTEAU L

Ref: THJ-PO3

Dim: 350 x 300 x 1960 mm





PUSH

Ref: THJ-DO1

Dim: 2313 x 760 x 1997 mm



PULL

Ref: THJ-DO2

Dim: 2314 x 742 x 1997 mm



SURFEUR

Ref: THJ-DO3

Dim: 1643 x 801 x 1997 mm



MARCHEUR

Ref: THJ-DO4

Dim: 2765 x 830 x 1997 mm

FITNESS MIX



LEG PRESS

Ref: THJ-DO5

Dim: 2359 x 550 x 1997 mm



VÉLO

Ref: THJ-DO6

Dim: 1961 x 1201 x 1997 mm



ADDUCTEUR ASSIS

Ref: THJ-DO7

Dim: 3130 x 1218 x 1997 mm



MASSEUR DOS

Ref: THJ-DO9

Dim: 1754 x 804 x 1997 mm





BANC ABDOS

Ref: THJ-DIOA

Dim: 1450 x 1533 x 1997 mm



LOMBAIRE

Ref: THJ-DIOL

Dim: 1850 x 821 x 1997 mm



VÉLO ELLIPTIQUE

Ref: THJ-DII

Dim: 3707 x 641 x 1997 mm



MASSEUR HANCHES

Ref: THJ-DI2H

Dim: 1700 x 765 x 1997 mm

FITNESS MIX



BARRES PARALLÈLES

Ref: THJ-DI3

Dim: 2394 x 714 x 1997 mm



ÉCHELLE À TRACTION

Ref: THJ-DI4E

Dim: 1152 x 998 x 2081 mm



CHAISE ROMAINE

Ref: THJ-DI4C

Dim: 2331 x 675 x 1997 mm



CAVALIER

Ref: THJ-DI5

Dim: 3159 x 665 x 1997 mm





RACK À TRACTION

Ref: THJ-D16

Dim: 1488 x 787 x 2174 mm



GRANDE ROUE

Ref: THJ-D18D

Dim: 1454 x 903 x 1997 mm



LEG STRETCH

Ref: THJ-D17

Dim: 1344 x 1080 x 2000 mm



ROUES TAI CHI

Ref: THJ-D18M

Dim: 1565 x 1154 x 1997 mm



FITNESS MIX



ARMS TRAINER

Ref: THJ-D19

Dim: 1344 x 989 x 2653 mm



MASSEUR ASSIS

Ref: THJ-D20

Dim: 2084 x 550 x 1997 mm



TWISTER

Ref: THJ-D21T

Dim: 1787 x 591 x 1997 mm



STEPPER

Ref: THJ-D21S

Dim: 1660 x 559 x 1997 mm





PATINEUR

Ref: THJ-D22

Dim: 3020 x 554 x 1997 mm



RAMEUR

Ref: THJ-D23

Dim: 2522 x 759 x 1997 mm



ADDUCTEUR

Ref: THJ-D24

Dim: 1950 x 653 x 1997 mm



MOULINET

Ref: THJ-D25

Dim: 1698 x 653 x 1997 mm





BICEPS

Ref: THJ-D26

Dim: 2605 x 526 x 1997 mm



LEG LIFT

Ref: THJ-D28

Dim: 2184 x 886 x 1997 mm



ARM PRESS

Ref: THJ-D29

Dim: 3494 x 774 x 1997 mm



LOW PULL UP

Ref: THJ-D30

Dim: 3652 x 672 x 1997 mm



NOS PACKS OUR PACKS

Nos packs sont l'associations de nos best-sellers pour créer des agrès complets et plus conviviaux. Ils permettent d'avoir moins d'emprise au sol.

Leurs prix sont disponibles à la demande.

Our packs are the combinations of our bestsellers to create complete and more user-friendly equipments. They allow you to occupy less space on the ground. Their prices are available on request.



PUSH + PULL + LEG PRESS + RAMEUR

Ref: THJ-DOI+DO2+DO5+D23

Dim: 2788 x 2716 x 1960 mm



PUSH + PULL + CHAISE + TRACTION

Ref: THJ-DOI+DO2+DI4C+DI6

Dim: 2643 x 2241 x 1960 mm



SURFEUR + LEG PRESS + VÉLO + CAVALIER

Ref: THJ-DO3+DO5+DO6+DI5

Dim: 3139 x 2209 x 1960 mm

FITNESS MIX

NOS PACKS OUR PACKS



LEG PRESS + VÉLO + PATINEUR

Ref: THJ-DO5+DO6+D22

Dim: 2649 x 2236 x 1967 mm



MARCHEUR + LEG PRESS + STEPPER

Ref: THJ-DO4+DO5+D21S

Dim: 2363 x 2354 x 1967 mm



VÉLO + ROUES TAI CHI + TWISTER

Ref: THJ-DO6+D18+D21T

Dim: 2161 x 1924 x 1967 mm



TWISTER + STEPPER + MOULINET

Ref: THJ-D21T+D21S+D25

Dim: 1769 x 1745x 1967 mm





FITNESS INOX



Fabrication en acier inoxydable (316) pour une grande durabilité dans tout type d'environnement.

Stainless steel (316) construction for a great longevity in all types of environments.



RAMEUR

Ref: SN-O1

Dim: 1319 x 930 x 1103 mm



VÉLO ELLIPTIQUE

Ref: SN-O3

Dim: 1300 x 636 x 1709 mm



LEG PRESS

Ref: SN-O4

Dim: 1865 x 895 x 2030 mm



SURFEUR

Ref: SN-O5

Dim: 1263 x 698 x 1540 mm

FITNESS INOX



BANC ABDOS

Ref: SN-O6

Dim: 1688 x 420 x 516 mm



ROUES TAI CHI

Ref: SN-O7

Dim: 1041 x 1042 x 1467 mm



DOUBLE TWISTER

Ref: SN-O8

Dim: 1498 x 784 x 1730 mm



MARCHEUR

Ref: SN-O9

Dim: 1248 x 500 x 1486 mm





MARCHEUR DOUBLE

Ref: SN-09 duo

Dim: 2338 x 500 x 1351 mm



VÉLO

Ref: SN-10

Dim: 1024 x 550 x 1329 mm



PUSH

Ref: SN-11

Dim: 1134 x 720 x 1830 mm



PULL

Ref: SN-12

Dim: 1316 x 1015 x 1830 mm

FITNESS INOX



PUSH + PULL

Ref: SN-11+SN-12

Dim: 2366x 1007 x 2257 mm



SURFEUR + TWISTER + MARCHEUR

Ref: SN-05 + SN-08 + SN-09

Dim: 2526 x 785 x 1470 mm





SENIOR PMR



Des appareils créés spécifiquement pour les seniors et les personnes à mobilité réduite.

A range of equipment created specifically for elderly and people with disabilities.

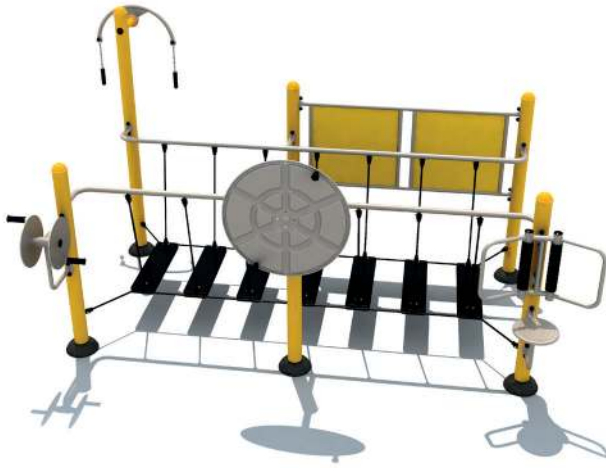

STATION EQUILIBRE

Ref: SEN-O1

Dim: 4282 x 2567 x 2500 mm

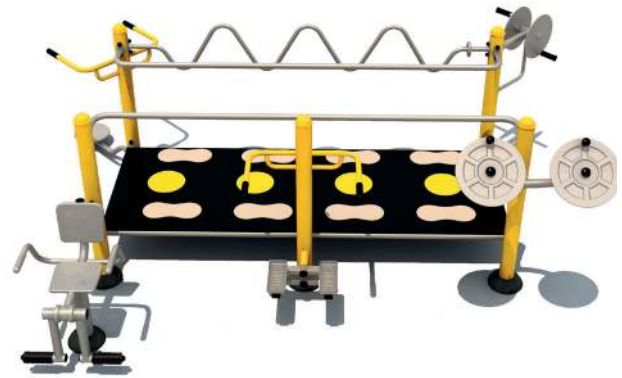

STATION MOBILITÉ

Ref: SEN-O2

Dim: 4176 x 3029 x 1450 mm



RAMPE

Ref: SEN-O3

Dim: 3118 x 1135 x 1850 mm



STATION RELAX

Ref: SEN-O4

Dim: 3492 x 2695 x 1700 mm



SENIOR + PMR



STATION BRAS

Ref: SEN-O5

Dim: 3700 x 1100 x 1700 mm

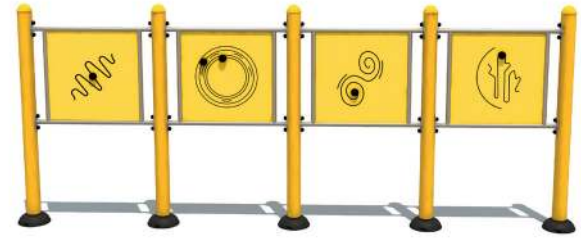

PANNEAUX JEUX

Ref: SEN-O6

Dim: 4390 x 114 x 1800 mm



POUTRE D'ÉQUILIBRE

Ref: SEN-O7

Dim: 1800 x 557 x 1250mm



SAUT DE HAIES

Ref: SEN-O8

Dim: 2814 x 1220 x 1250 mm





JEUX DE MOBILITÉ

Ref: SEN-09

Dim: 2300 x 2550 x 1050 mm



NOUVEAUTÉ

PLATEFORME D'ÉQUILIBRE

Ref: SEN-13

Dim: 1614 x 600 x 1700 mm



NOUVEAUTÉ

ASSIS DEBOUT

Ref: SEN-15

Dim: 1614 x 1057 x 1200 mm



4 EN 1

Ref: KOMBI4INI

Dim: 1521 x 994 x 1249 mm



SENIOR + PMR



PUSH PMR

Ref: THJ-DO1/N

Dim: 1718 x 801 x 1997 mm



PULL PMR

Ref: THJ-DO2/N

Dim: 2111 x 742 x 1997 m



ÉPAULES PMR

Ref: THJ-DO3/N

Dim: 1525 x 682 x 1997 mm



TRACTION STRETCH PMR

Ref: THJ-DI6/N

Dim: 1678 x 790 x 1997 mm





GRANDES ROUES

Ref: THJ-DI8D/N

Dim: 1445 x 900 x 1997 mm



ROUES TAI CHI

Ref: THJ-DI8M/N

Dim: 1566 x 1155 x 1997 mm



ARMS TRAINER PMR

Ref: THJ-DI9/N

Dim: 1280 x 790 x 1997 mm



STEPPER PMR

Ref: THJ-D21/N

Dim: 2295 x 657 x 1997 mm



SENIOR + PMR



PATINEUR PMR

Ref: THJ-D22/N

Dim: 889 x 843 x 1376 mm



MOULINET

Ref: THJ-D25/N

Dim: 1580 x 650 x 1997 mm



MOULINET

Ref: THJ-D25-2/N

Dim: 1698 x 630 x 1997 mm



BICEPS PMR

Ref: THJ-D26/N

Dim: 1430 x 600 x 1997 mm





PISTON



Règlez la dureté du piston pour mettre un peu de challenge dans votre entraînement quotidien.

Put a little bit of challenge in your daily training thanks to our adjustable pistons.



ABDOS

Ref: HEH-O2

Dim: 1133 x 614 x 1533 mm



LEG PRESS

Ref: HEH-O3

Dim: 1325 x 646 x 1533 mm



SQUAT

Ref: HEH-O4

Dim: 1125 x 766 x 1533 mm



ADDUCTEUR

Ref: HEH-O5

Dim: 1461 x 1050 x 1533 mm



TRICEPS

Ref: HEH-O8

Dim: 922 x 642 x 1533 mm



CHEST PRESS

Ref: HEH-O9

Dim: 1072 x 642 x 1533 mm



PUSH

Ref: HEH-10

Dim: 1065 x 642 x 1532 mm



EPAULES

Ref: HEH-11

Dim: 1065 x 1007 x 1533 mm





BICEPS

Ref: HEH-12

Dim: 958 x 640 x 1153 mm



TWISTER

Ref: HEH-13

Dim: 1344 x 802 x 1533 mm



RAMEUR

Ref: HEH-14

Dim: 1297 x 692 x 1247 mm



STEPPER

Ref: HEH-15

Dim: 1106 x 664 x 1531 mm

PISTON



BENCH

Ref: HEH-16

Dim: 1411 x 896 x 1193 mm



CUISES

Ref: HEH-17

Dim: 1215 x 666 x 1533 mm



VÉLO

Ref: HEH-18

Dim: 1423 x 587 x 1533 mm



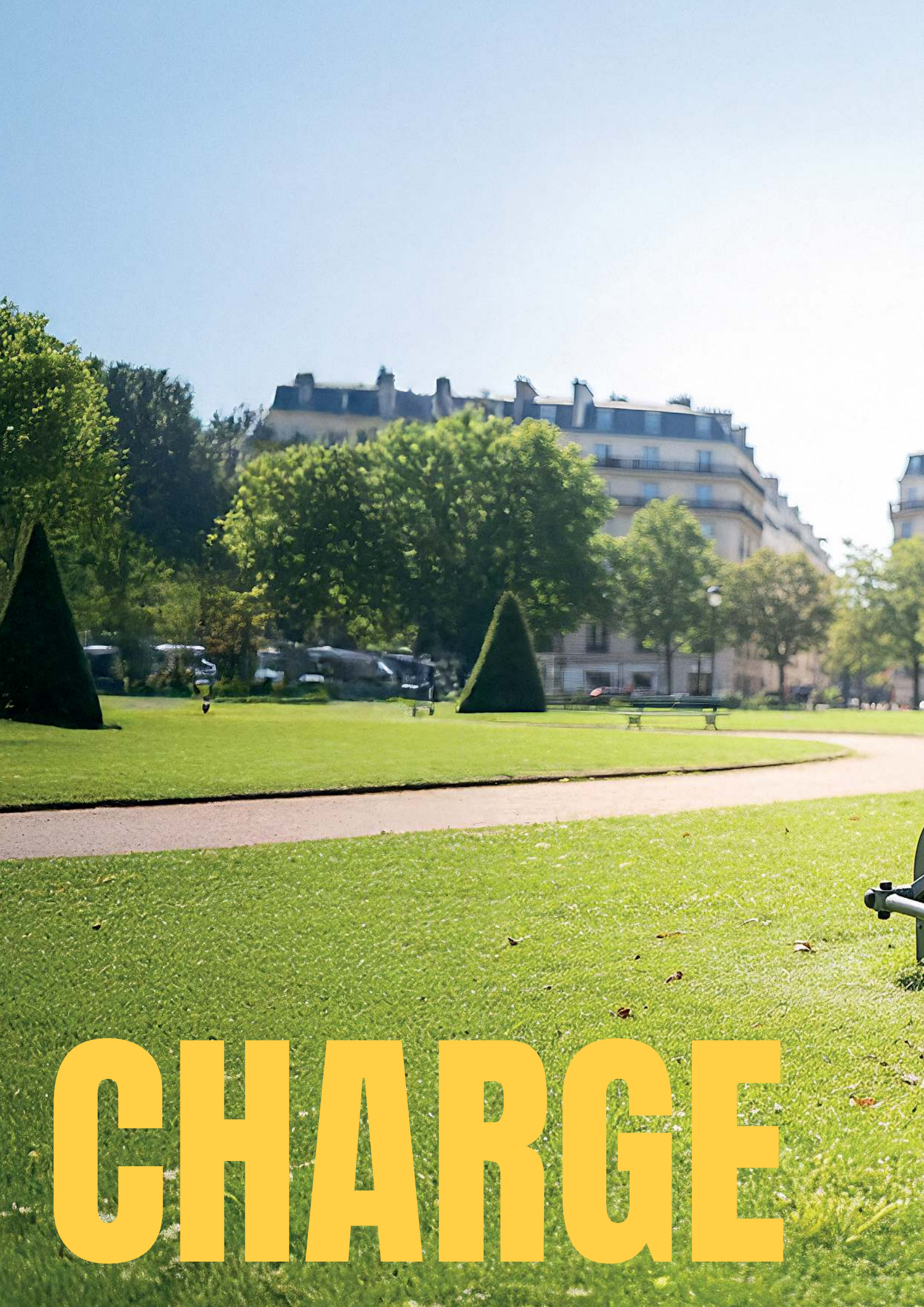

CHARGE



Ajustez la difficulté avec notre résistance magnétique, tout en rechargeant votre téléphone en USB ou par induction.

Adjust the difficulty thank to the magnetic resistance, while charging your phone via USB or wireless charging.

Les agrès Charge sont également disponibles sans système de chargement de téléphones, comprenant simplement la résistance réglable sur 5 niveaux.

Charge equipments are also available without the phone charging system, simply including the 5-level adjustable resistance.



Instructions détaillées + QR code / Detailed instructions + QR code



Zone de chargement induction / Induction charging area



Prise USB 2.0A / USB 2.0A socket



Molette de réglage de la résistance / Resistance adjustment knob



VÉLO ELLIPTIQUE

Ref: USB-O1

Dim: 2400 x 580 x 1655 mm



VÉLO

Ref: USB-O2

Dim: 1800 x 728 x 1306 mm

CHARGE



VÉLO BRAS

Ref: USB-O3

Dim: 1657 x 639 x 1276 mm



STEPPER

Ref: USB-O4

Dim: 976 x 500 x 1356 mm



SQUAT

Ref: USB-O5

Dim: 1327 x 460 x 1276 mm



RAMEUR

Ref: USB-O6

Dim: 1700 x 822 x 1276 mm





CHEST PRESS

Ref: USB-O7

Dim: 834 x 822 x 1276 mm



TIRAGE VERTICAL

Ref: USB-O8

Dim: 998 x 822 x 1615 mm



PRESSE ÉPAULES

Ref: USB-O9

Dim: 980 x 822 x 1276 mm



PAPILLON

Ref: USB-IO

Dim: 979 x 640 x 1390 mm

CHARGE



ADDUCTEUR

Ref: USB-11

Dim: 1122 x 419 x 1276 mm



LEG LIFT

Ref: USB-12

Dim: 1129 x 725 x 1306 mm



DEAD LIFT

Ref: USB-13

Dim: 1298 x 435 x 1276 mm



TRICEPS

Ref: USB-14

Dim: 837 x 602 x 1276 mm





BODY BUILDING



Une gamme conçue pour la progression, avec des poids réglables et sécurisés pour un entraînement poussé, en plein air, comme à la salle.

A range dedicated to progression, with adjustable and secured weights, for an intense outdoor workout.



CHEST PRESS

Ref: HE-O1

Dim: 1270 x 1147 x 1555 mm



ÉPAULES

Ref: HE-O2

Dim: 1270 x 1103 x 1915 mm



DEAD LIFT

Ref: HE-O3

Dim: 1270 x 1227 x 1677 mm



BACK PRESS

Ref: HE-O4

Dim: 1610 x 1350 x 2445 mm

BODYBUILDING



PAPILLON

Ref: HE-O5

Dim: 1670 x 1350 x 2180 mm



CUISSES

Ref: HE-O6

Dim: 1350 x 1112 x 1414 mm



LEG PRESS

Ref: HE-O7

Dim: 1270 x 1282 x 1690 mm



SQUAT

Ref: HE-O8

Dim: 1419 x 1160 x 1345 mm





Chaque machine est livrée avec des poids standards de 2x 5 kg sur chaque bras. Les poids peuvent être ajoutées ou modifiées à 10 kg si nécessaire.

Each machine comes with a standard 2x 5kg plate on each arm. Plates can be added or modified to 10kg if needed.

BENCH PRESS

Ref: HE-O9

Dim: 1270 x 1620 x 1157mm

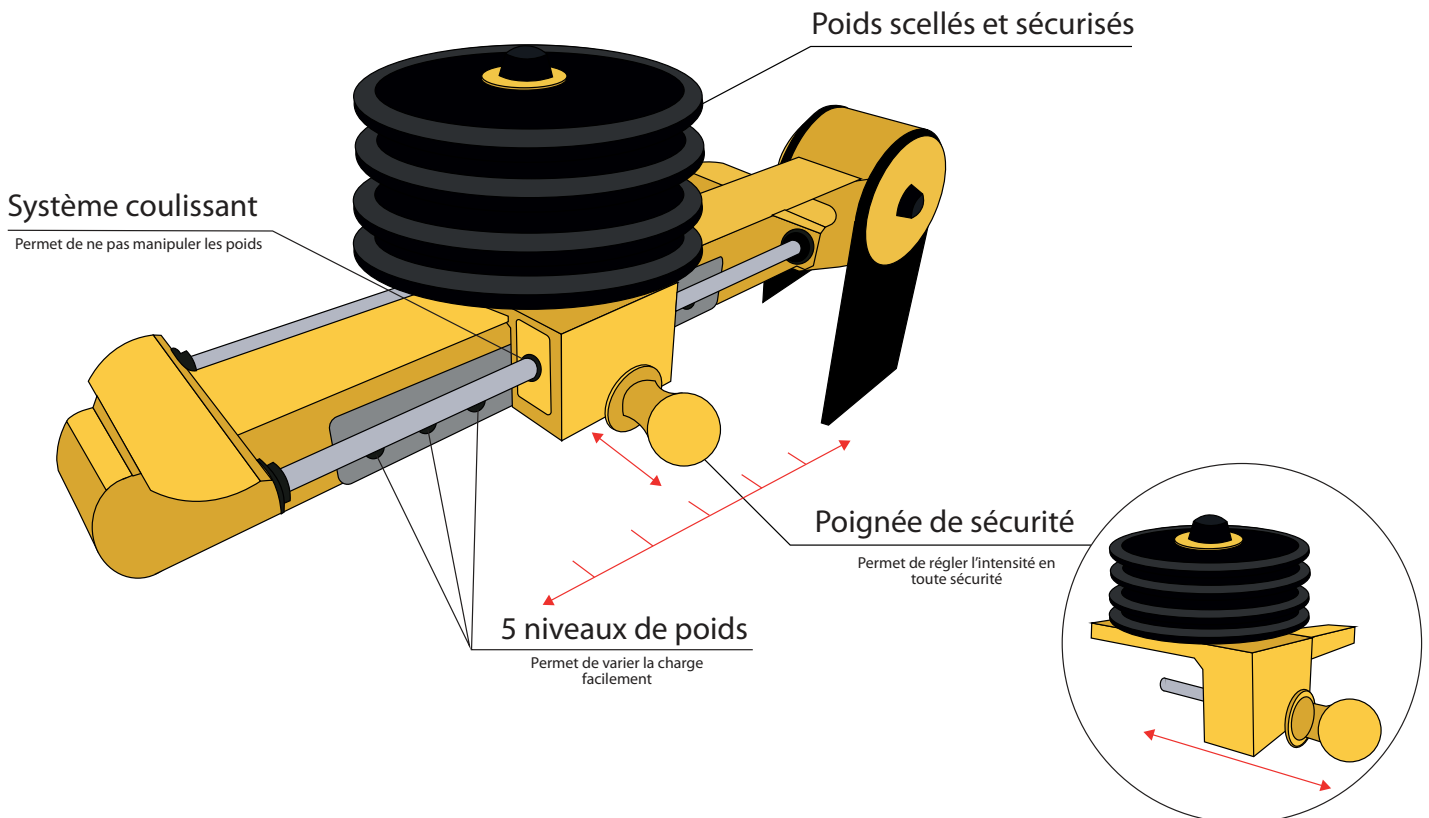

BODYBUILDING



**S'entraîner,
comme à la salle !**

WORKOUT



STATION CROSS TRAINING

Ref: HER-O1

Dim: 5837 x 3890 x 3628 mm



STATION STREET

Ref: HER-O2

Dim: 5960 x 4154 x 2934 mm



STATION GYM

Ref: HER-O3

Dim: 6888 x 4347 x 3729 mm



STATION PARCOURS

Ref: HER-O4

Dim: 5870 x 4656 x 3045 mm

STREET WORKOUT



STATION FIT

Ref: HER-O5

Dim: 7466 x 3163 x 2545 mm



STATION GYMNASTIQUE

Ref: HER-O6

Dim: 9764 x 3159 x 2545 mm



STATION ETOILE

Ref: HER-O7

Dim: 3300 x 3300 x 2540 mm



STATION SUSPENDUE

Ref: HER-O8

Dim: 7500 x 1800 x 2540 mm





STATION MUR

Ref: HER-09

Dim: 7798 x 300 x 2551 mm



BARRES MIX

Ref: HER-10

Dim: 4797 x 300 x 2550 mm

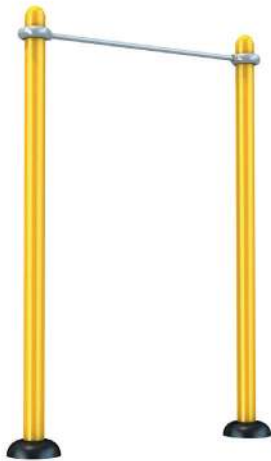

BARRE SIMPLE

Ref: HER-10-2

Dim: 1799 x 300 x 2550 mm



BARRE DOUBLE

Ref: HER-10-3

Dim: 3156 x 300 x 2545 mm



BARRE TRIPLE

Ref: HER-10-4

Dim: 4657 x 170 x 2545 mm



STATION SNAKE

Ref: HER-11

Dim: 5000 x 3000 x 2255 mm



STATION INTÉGRÉE

Ref: HER-12

Dim: 7826 x 4545 x 3012 mm



SET ABDOS

Ref: HER-13

Dim: 3844 x 1648 x 2517 mm





MINI BARRES À POMPES

Ref: HER-14

Dim: 580 x 392 x 220 mm



BARRES À POMPES

Ref: HER-14-2

Dim: 590 x 1032 x 315 mm



STEP PLIO S

Ref: HER-15-2

Dim: 500 x 500 x 250 mm



STEP PLIO M

Ref: HER-15-3

Dim: 2750 x 500 x 400 mm

STREET WORKOUT



STEP PLIO L

Ref: HER-15-4

Dim: 500 x 500 x 550 mm



STATION SOL

Ref: HER-16

Dim: 6095 x 1666 x 1154 mm



TRIPLE BARRES PARALLÈLES

Ref: HER-16-2

Dim: 1565 x 1289 x 1122 mm



BARRES PARALLÈLES DOUBLES

Ref: HER-17

Dim: 4080 x 772 x 1730 mm





BARRES PARALLÈLES

Ref: HER-17-2

Dim: 1760 x 860 x 1713 mm

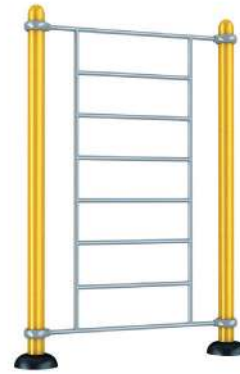

ÉCHELLE VERTICALE

Ref: HER-18

Dim: 1656 x 170 x 2545 mm



ÉCHELLE HORIZONTALE

Ref: HER-19

Dim: 2400 x 1800 x 2555 mm

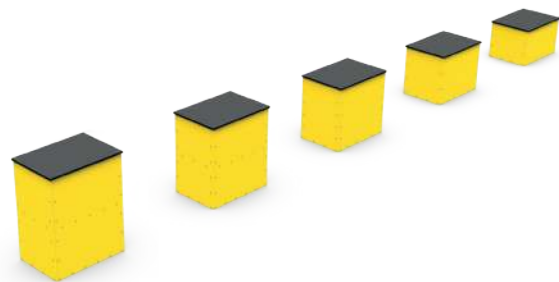

JUMP BOX

Ref: HER-20

Dim: 630 x 450 x 400-800

STREET WORKOUT

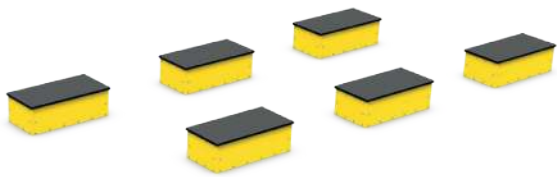

JUMP OBSTACLES

Ref: HER-21

Dim: 300 x 600 x 200 mm



ETOILE DE RYTHME

Ref: HER-22

Dim: 500x20mm & 200x70mm (4x)

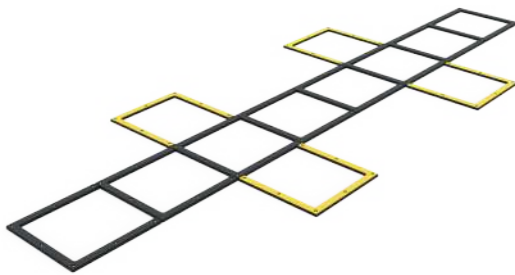

ÉCHELLE DE RYTHME

Ref: HER-23

Dim: 4800 x 1800 x 20 mm



SLALOM

Ref: HER-24

Dim: 200 x 200 x 70 mm (10x)





ANNEAUX DE RYTHME

Ref: HER-25

Dim: 500 x 500 x 20 mm



STATION PMR

Ref: HER-26

Dim: 5400 x 3100 x 2500 mm



POUTRE

Ref: HER-27

Dim: 2000 x 130 x 430 mm



STEP FITNESS

Ref: HER-29

Dim: 500 x 300 x 200-600 mm

STREET WORKOUT

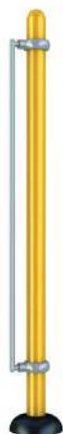

NOUVEAUTÉ

POTEAU DRAPEAU

Ref: HER-33

Dim: 496 x 325 x 2524 mm



NOUVEAUTÉ

POUTRE SUSPENDUE

Ref: HER-35

Dim: 2120 x 720 x 925 mm



NOUVEAUTÉ

BARRES PARALLÈLES PMR

Ref: HER-36

Dim: 2120 x 1220 x 925 mm

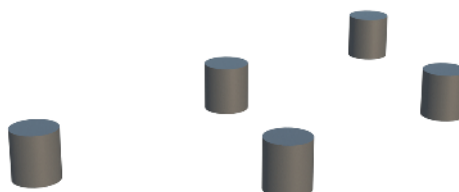

NOUVEAUTÉ

PAS JAPONAIS

Ref: HER-40

Dim: 140 x 140 x 150 mm (5x)



NOUVEAUTÉ



KICKBOX

Ref: HER-41

Dim: 340 x 340 x 1877 mm



CORDES

Ref: HER-43

Dim: 7154 x 550 x 1200 mm



CORDE À GRIMPER

Ref: HER-51

Dim: 1057 x 260 x 3026 mm

STREET WORKOUT

Véritables lieux de vie, les stations Street Workout attirent naturellement sportifs, familles et curieux. L'exemple de Riorges en témoigne : l'inauguration a rassemblé une foule enthousiaste autour de ces nouveaux espaces dynamiques.

True community hubs, Street Workout stations naturally attract athletes, families and onlookers. The Riorges inauguration is proof: the new spaces gathered a vibrant, enthusiastic crowd.



MINI



Une série adaptée à nos plus jeunes utilisateurs pour pouvoir travailler leur mobilité, développer leurs intérêts sportifs, tout en luttant contre la sédentarité et l'obésité.

A series designed for our youngest users to improve mobility, spark interest in sports, and promote an active lifestyle while combating inactivity and obesity.

Conçus pour stimuler la mobilité et le jeu actif, les agrès Mini sont adaptés aux plus jeunes sans effort musculaire intense. Robustes et conformes à la norme EN1176, ils assurent sécurité et durabilité.

Specially designed to develop mobility and coordination, Mini equipment encourages active play without intense muscle effort. Durable and EN1176 compliant, it ensures daily safety and long-lasting use.



Jeu actif et sécurisé / Active and safe play



Conformes à la norme EN1176 / EN1176 Compliant



Robustes et personnalisables / Durable and customizable



Pour écoles et aires de jeux / Perfect for schools and playgrounds





VÉLO MINI

Ref: MAL-O3

Dim: 790 x 280 x 1137 mm



SURFEUR MINI

Ref: MAL-O4

Dim: 1618 x 752 x 1255 mm



MARCHEUR MINI

Ref: MAL-O1

Dim: 1425 x 638 x 1255 mm



TAI CHI MINI

Ref: MAL-O2

Dim: 1113 x 960 x 955 mm





NINJA

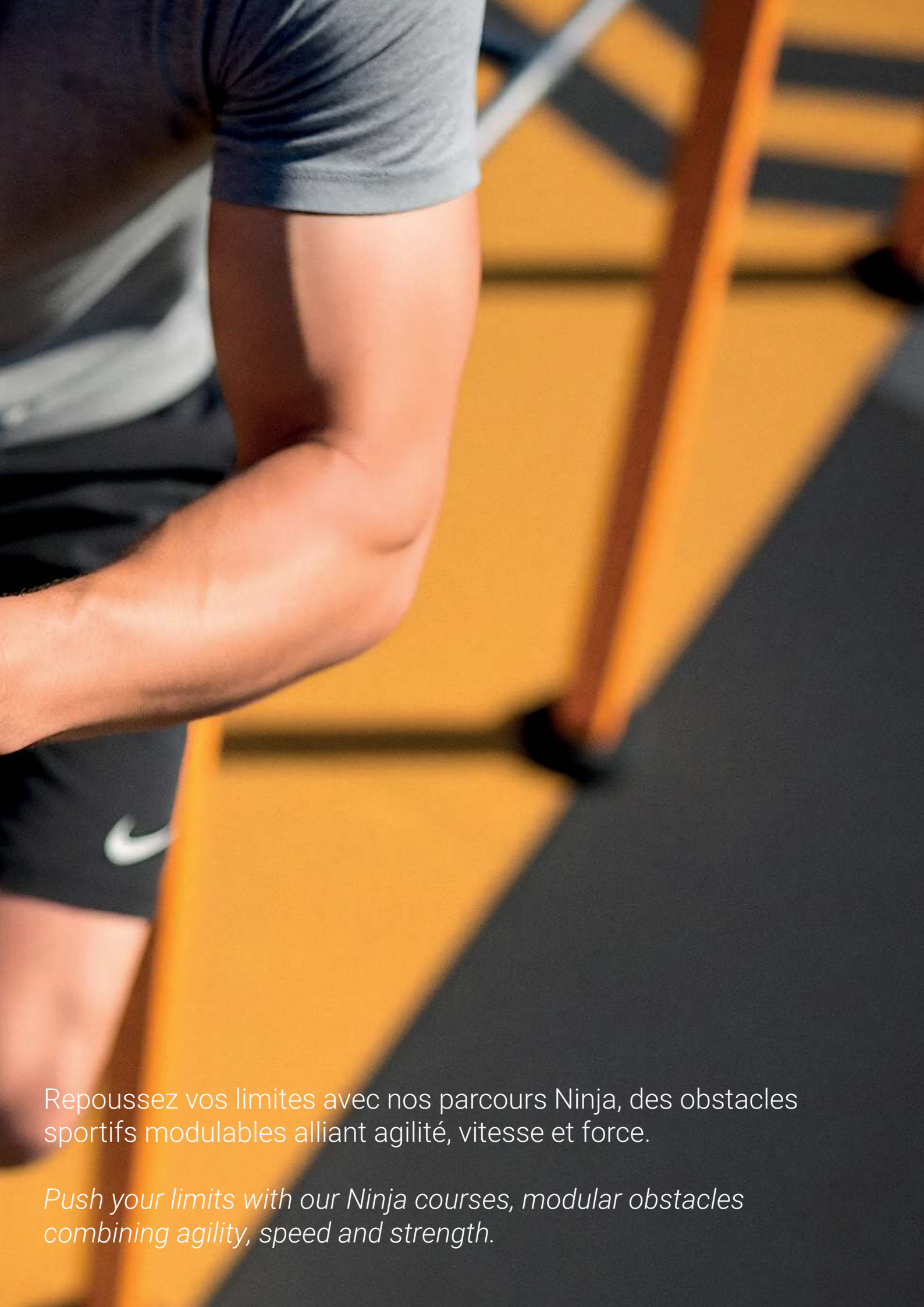

Repoussez vos limites avec nos parcours Ninja, des obstacles sportifs modulables alliant agilité, vitesse et force.

Push your limits with our Ninja courses, modular obstacles combining agility, speed and strength.



PARCOURS COMPLET

Ref: NJA-00

Dim: 18860 x 8800 x 3330 mm

NOUVEAUTÉ



PLANS INCLINÉS

Ref: NJA-01

Dim: 2220 x 906 x 400 mm

NOUVEAUTÉ



PASSAGE DE ROUES

Ref: HER-55

Dim: 5284 x 1790 x 2349 mm

NINJA



TRIPLE POUTRES

Ref: NJA-O3

Dim: 2100 x 1005 x 319 mm



SKYWALK

Ref: NJA-O4

Dim: 2932 x 695 x 2720 mm



BARRES NINJA

Ref: NJA-O6

Dim: 2408 x 1827 x 2565 mm



POUTRE DESSUS DESSOUS

Ref: NJA-O7

Dim: 2114 x 1714 x 1630 mm





AGILITY



Partagez des moments sportifs avec votre chien grâce à nos agrès agility.

Share an active moment with your dog thanks to our agility obstacles!

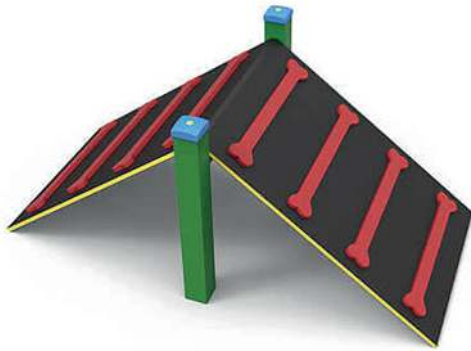

PETIT BRIDGE

Ref: AGO1

Dim: 1622 x 860 x 720 mm

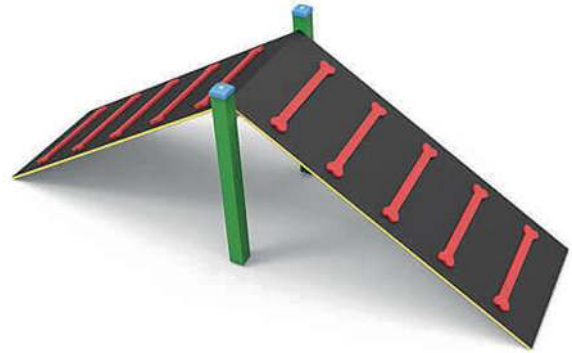

GRAND BRIDGE

Ref: AGO2

Dim: 3200 x 920 x 1100 mm

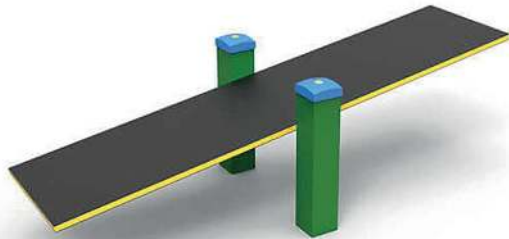

PETITE BALANCE

Ref: AGO3

Dim: 540 x 1400 x 410 mm

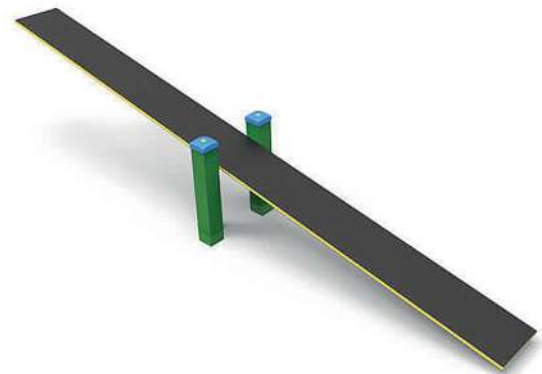

GRAND PONT À BASCULE

Ref: AGO4

Dim: 410 x 3000 x 5100 mm



A-FRAME

Ref: AGO5/A

Dim: 5910 x 966 x 860 mm



A-FRAME "Z"

Ref: AGO5/B

Dim: 3500 x 1200 x 600 mm



PETITE PLATEFORME

Ref: AGO6

Dim: 910 x 1080 x 410 mm



GRANDE PLATEFORME

Ref: AGO7

Dim: 9120 x 1078 x 610 mm



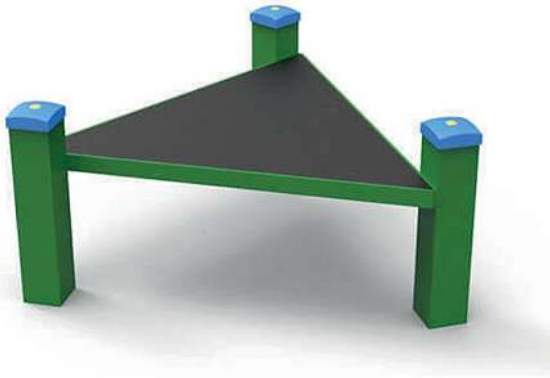

PETIT TRIANGLE

Ref: AGO8

Dim: 830 x 880 x 410 mm



GRAND TRIANGLE

Ref: AGO9

Dim: 830 x 880 x 610 mm



TRIPLE STAND

Ref: AG10

Dim: 750 x 800 x 200; 300;
400 mm



CHAMPIGNONS

Ref: AG11

Dim: 380 x 3900 x 200; 300;
400 mm

AGILITY



OBSTACLES OS

Ref: AGI2

Dim: 98 x 900 x 490 mm



OBSTACLES PATTES

Ref: AGI3

Dim: 100 x 900 x 410 mm

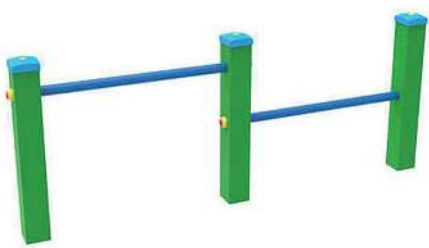

BARRES

Ref: AGI4

Dim: 1560 x 90 x 610 mm

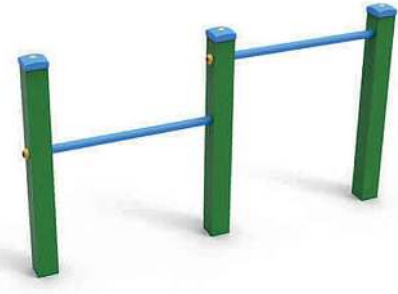

BARRES HAUTES

Ref: AGI5

Dim: 1560 x 90 x 870 mm



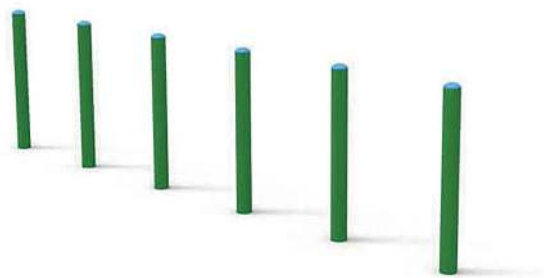

SLALOM

Ref: AG16/A

Dim: 60 x 3360 x 820 mm



PISTE TUBE

Ref: AG16/B

Dim: 1866 x 3375 x 600 mm



BARRES DE SAUT 5 NIVEAUX

Ref: AG17

Dim: 1523 x 283 x 780 mm



BARRES DE SAUT 3 NIVEAUX

Ref: AG18

Dim: 1523 x 283 x 780 mm



ANNEAUX TRIANGLE

Ref: AG19

Dim: 42 x 1211 x 1530 mm

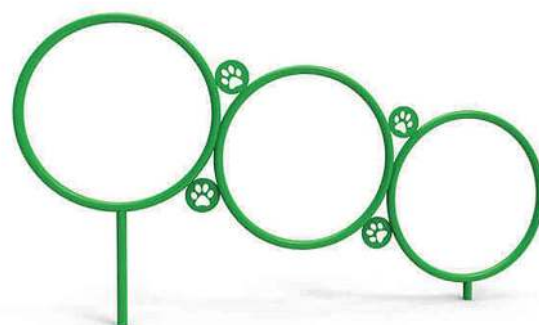

ANNEAUX LIGNE

Ref: AG20

Dim: 42 x 2430 x 1320 mm



3 CERCLES

Ref: AG21/A

Dim: 110 x 1700 x 1000 mm

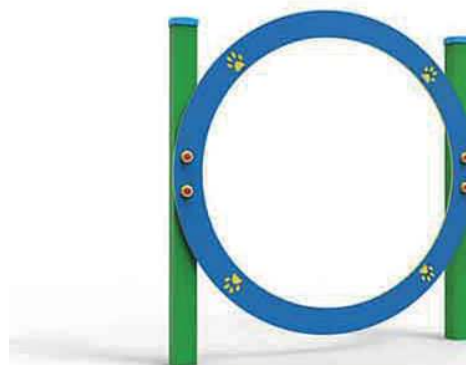

CERCLE SIMPLE

Ref: AG21/B

Dim: 1200 x 100 x 1200 mm





CERCLE FLOT

Ref: AG22

Dim: 140 x 1188 x 1520 mm



PATTE

Ref: AG23

Dim: 116 x 1481 x 1700 mm



TUNNEL BUDA

Ref: AG24

Dim: 1180 x 1043 x 1110 mm



TUBE MAISON

Ref: AG25

Dim: 1263 x 1200 x 1150 mm

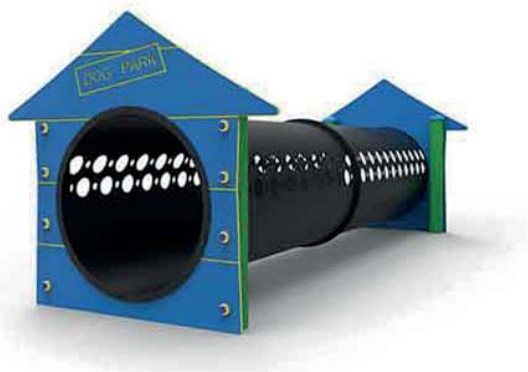

TUUNNEL MAISON

Ref: AG25/B

Dim: 1263 x 3008 x 1150 mm



TUNNEL NICHE PETIT

Ref: AG26

Dim: 1040 x 1050 x 980 mm



TUNNEL NICHE GRAND

Ref: AG27

Dim: 1510 x 1050 x 980 mm



TUNNEL REX

Ref: AG28

Dim: 1190 x 1190 x 1430 mm





TUNNEL REX

Ref: AG28

Dim: 1180 x 1190 x 1430 mm



TUNNEL FIGIEL

Ref: AG28/B

Dim: 1200 x 1400 x 1100 mm



A-FRAME GRAND

Ref: AG29

Dim: 5020 x 300 x 1020 mm



CERCEAU

Ref: AG30

Dim: 1400 x 900 x 1820 mm

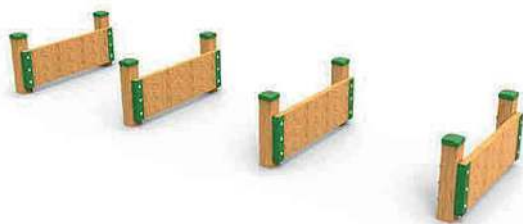

PETITS MURS

Ref: AG32

Dim: 790 x 280 x 1137 mm

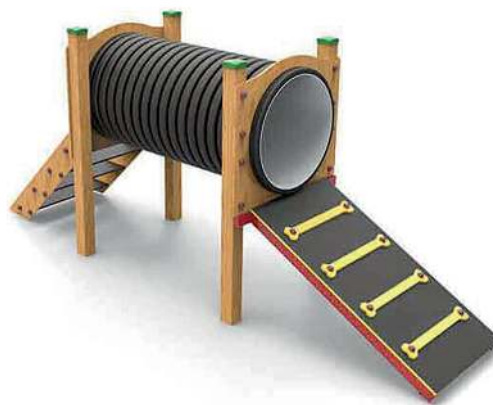

TUBE

Ref: AG33

Dim: 790 x 280 x 1137 mm



TRIPLE PLATEFORME

Ref: AG34

Dim: 790 x 280 x 1137 mm



DOG PARK I

Ref: AG35

Dim: 790 x 280 x 1137 mm



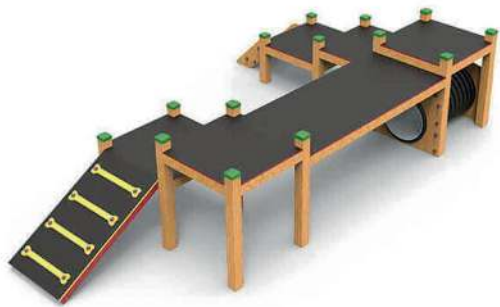

DOG PARK 2

Ref: AG36

Dim: 790 x 280 x 1137 mm

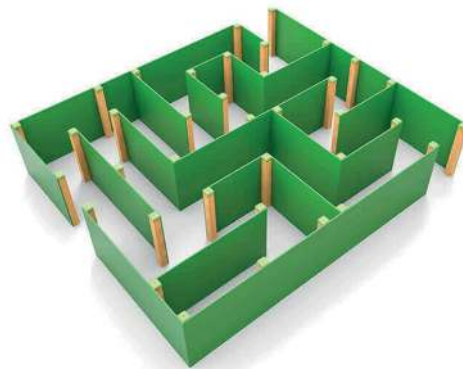

LABYRINTHE

Ref: AG37

Dim: 790 x 280 x 1137 mm



ATTACHE CHIEN PATTE

Ref: AG48

Dim: 790 x 280 x 1137 mm



PORTE LAISSE OS

Ref: AG49

Dim: 790 x 280 x 1137 mm



BANC AVEC DOSSIER OS

Ref: AG53

Dim: 790 x 280 x 1137 mm



BANC SIMPLE OS

Ref: AG54

Dim: 790 x 280 x 1137 mm



CASSETTE NOIRE

Ref: AG46

Dim: 790 x 280 x 1137 mm



CASSETTE INOX

Ref: AG61

Dim: 790 x 280 x 1137 mm





POUBELLE AVEC DISTRIBUTEUR

Ref: AG44

Dim: 790 x 280 x 1137 mm



PANNEAU D'INFO

Ref: AG50

Dim: 790 x 280 x 1137 mm



ABRI BOIS

Ref: ABI

Dim: 4230 x 2000 x 2300 mm



ABRI MÉTAL

Ref: ABII

Dim: 2500 x 2070 x 2130 mm

AGILITY



FONTAINE D'EAU

Ref: AG58

Dim: Ø330 x 1051 mm



FONTAINE FIGIEL

Ref: AG52

Dim: 470 x 750 x 670 mm



TOILETTES POUR CHIEN

Ref: AG41

Dim: Ø330 x 600 mm

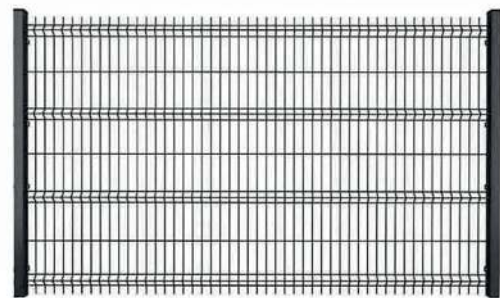

CLOTURE

Ref: CL

Dim: /



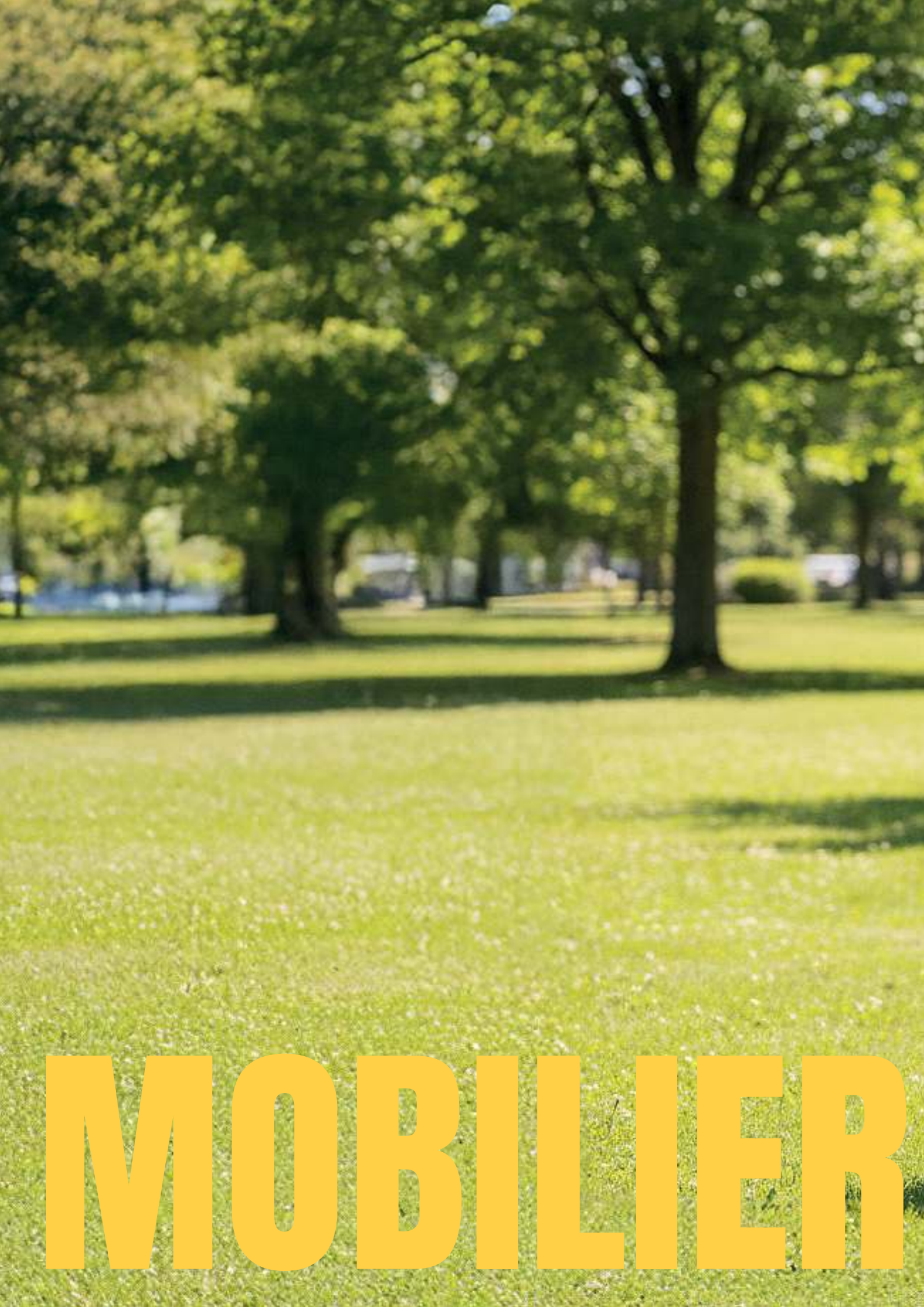

MOBILIER

ZONE DE SPORT

WBS

QR CODE

1	2	3	4
5	6	7	8

CONTACT

WEBSITE

Tout ce dont vous pourriez avoir besoin à côté de votre parc fitness extérieur.

Anything that you may need next to your fitness park.

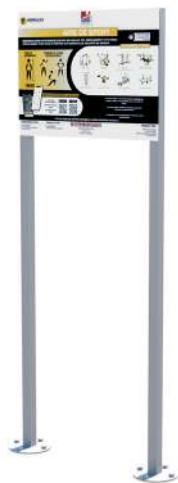

PANNEAU D'INFO

Ref: TI-O1

Dim: 800 x 50 x 2000 mm



PETIT PANNEAU

Ref: TI-O2

Dim: 226 x 50 x 1400



VESTIAIRE

Ref: BNC-O2

Dim: 7154 x 550 x 1200 mm



SHELTER SIMPLE

Ref: SHT-O1

Dim: 2100 x 2700 x 2750 mm

MOBILIER



TABLE D'ÉCHECS SIMPLE

Ref: TBL-O1

Dim: 1758 x 1758 x 769 mm



TABLE D'ÉCHECS DOUBLE

Ref: TBL-O2

Dim: 1755 x 1330 x 768 mm

COLORIS AU CHOIX



BANC CLASSIQUE

Ref: BNC-O1

Dim: 1820 x 550 x 760 mm

COLORIS AU CHOIX



BANC LUXE

Ref: BNC-O3

Dim: 1820 x 550 x 760 mm







Herkules Fitness
Île du Platais 78670
Villennes-sur-Seine France

+33 (0)1 84 60 23 30
contact@herkules.fr
www.herkules-fitness.com



HERKULES
FITNESS EN PLEIN AIR